

CH1 CH2 0-5V  
CH3 CH4 4-20mA

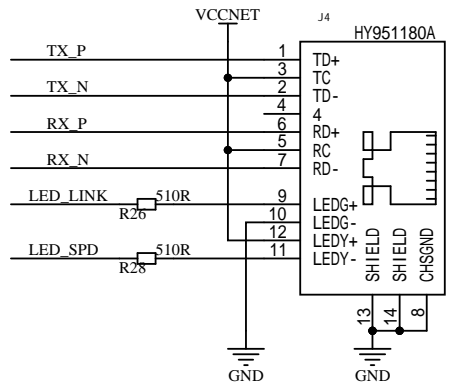

Title		
Size A4	Number	Revision
Date: 3/13/2023	Sheet of	
File: G:\KC868-A256\ADC&ETH.SchDoc	Drawn By:	

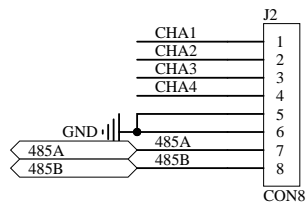
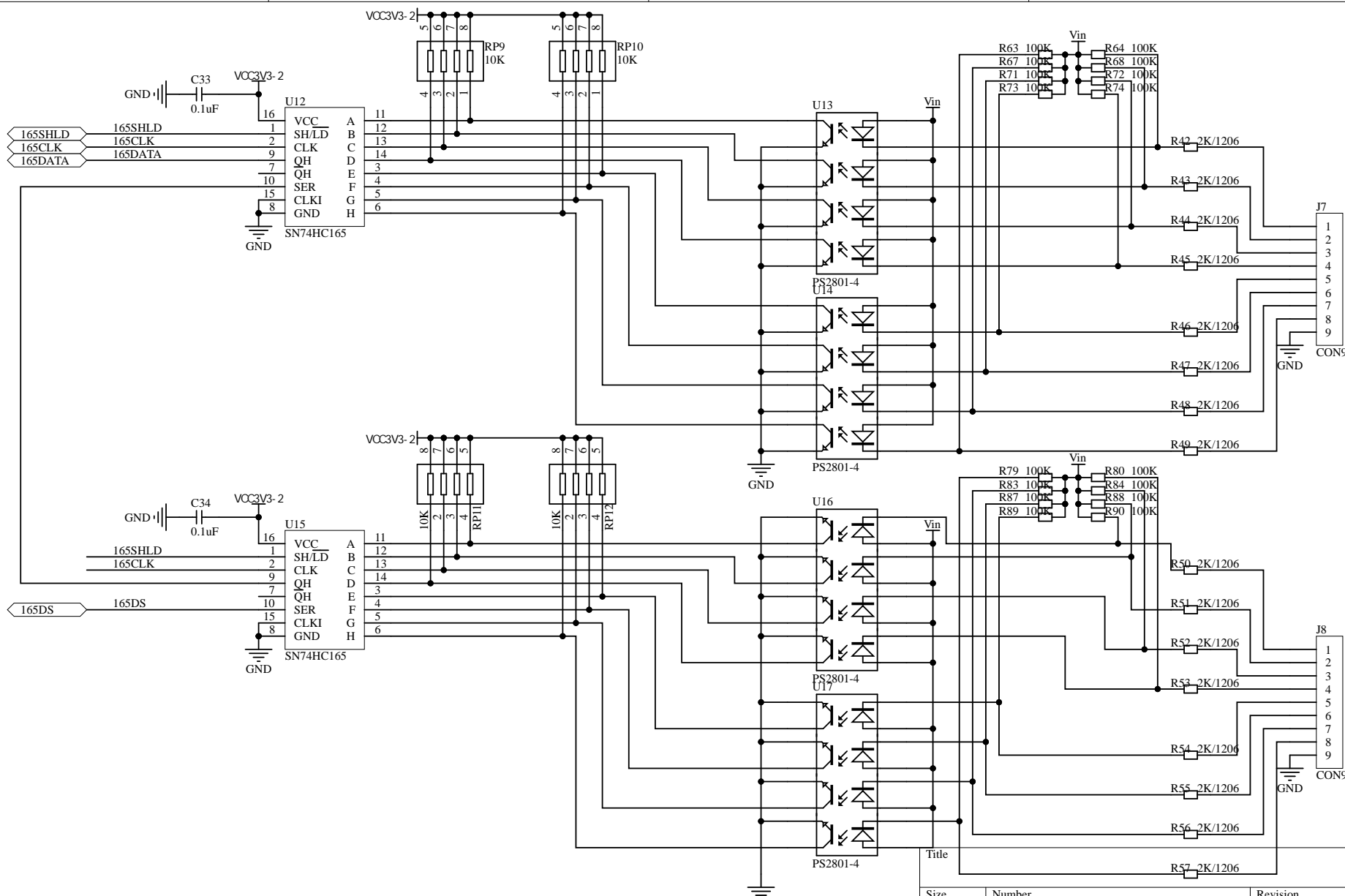

Title		
Size	Number	Revision
A4		
Date:	3/13/2023	Sheet of
File:	G:\KC868-A256\I.SchDoc	Drawn By:

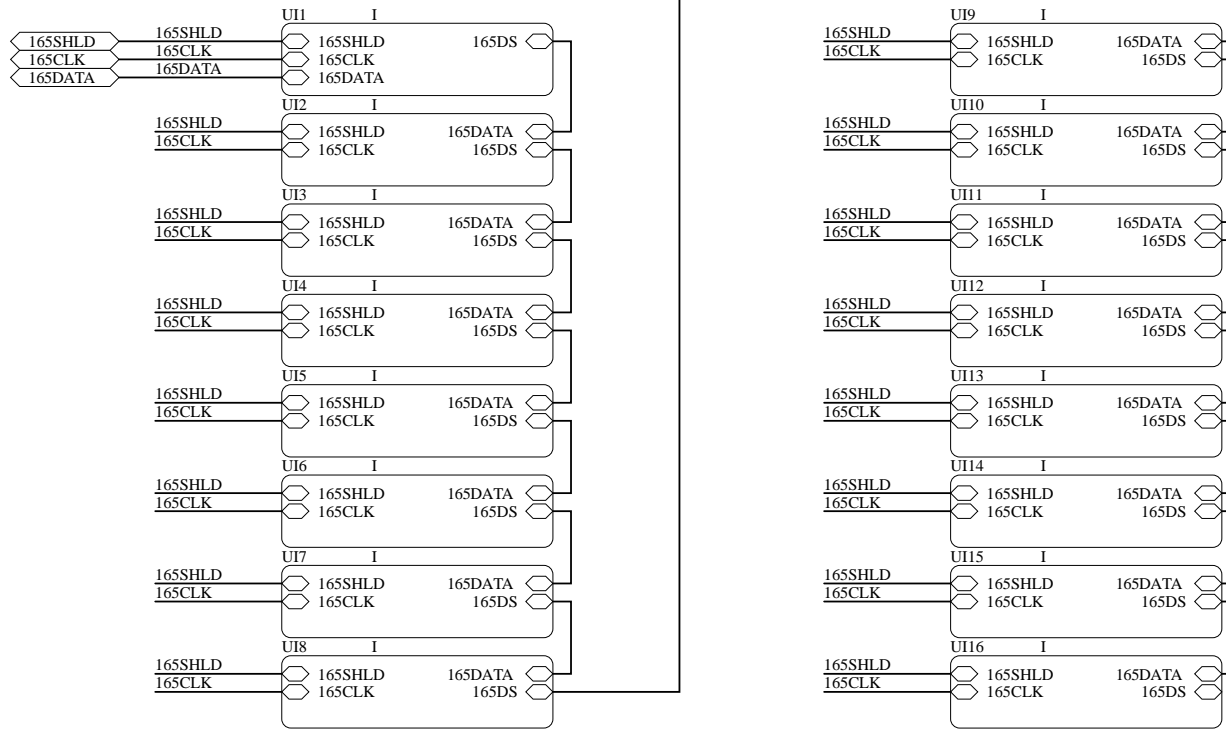

Title		
Size A4	Number	Revision
Date:	3/13/2023	Sheet of
File:	G:\KC868-A256\IN.SchDoc	Drawn By:

1

2

3

4

A

A

B

B

C

C

D

D

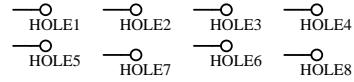
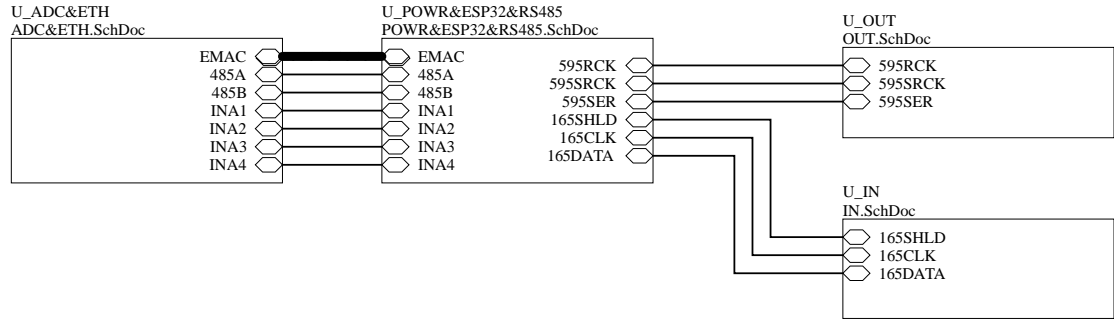

Title		
Size A4	Number	Revision
Date: 3/13/2023	Sheet of	
File: G:\KC868-A256\KC868-A256.SchDoc	Drawn By:	

1

2

3

4

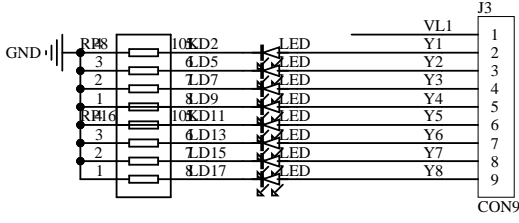
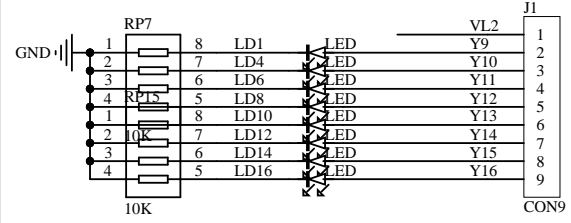
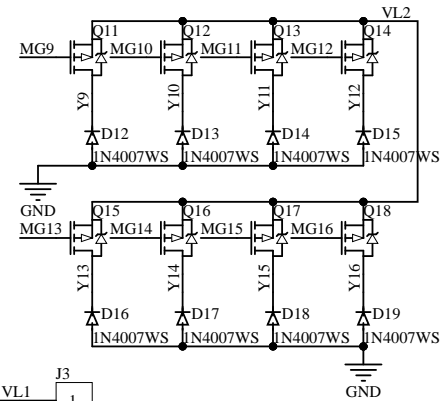
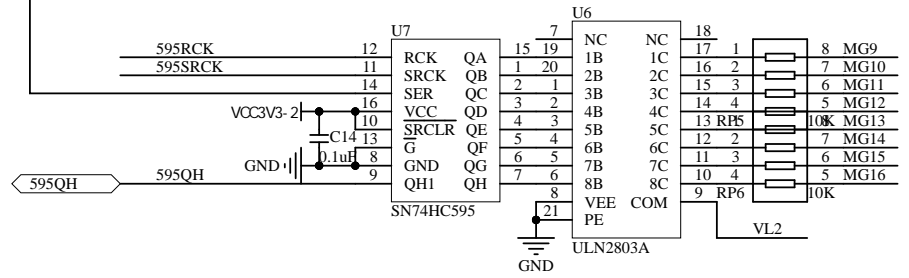
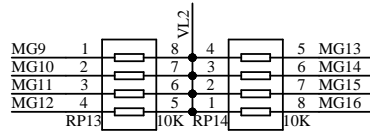
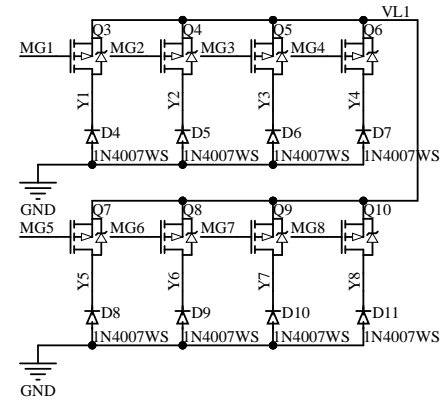
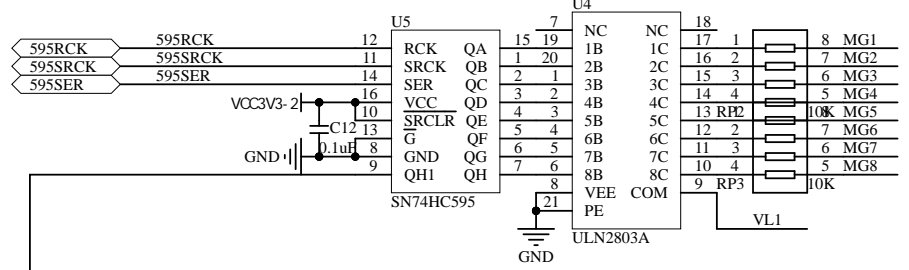
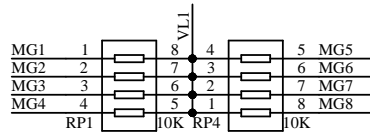

Title		
Size	Number	Revision
A4		
Date:	3/13/2023	Sheet of
File:	G:\KC868-A256\O.SchDoc	Drawn By:

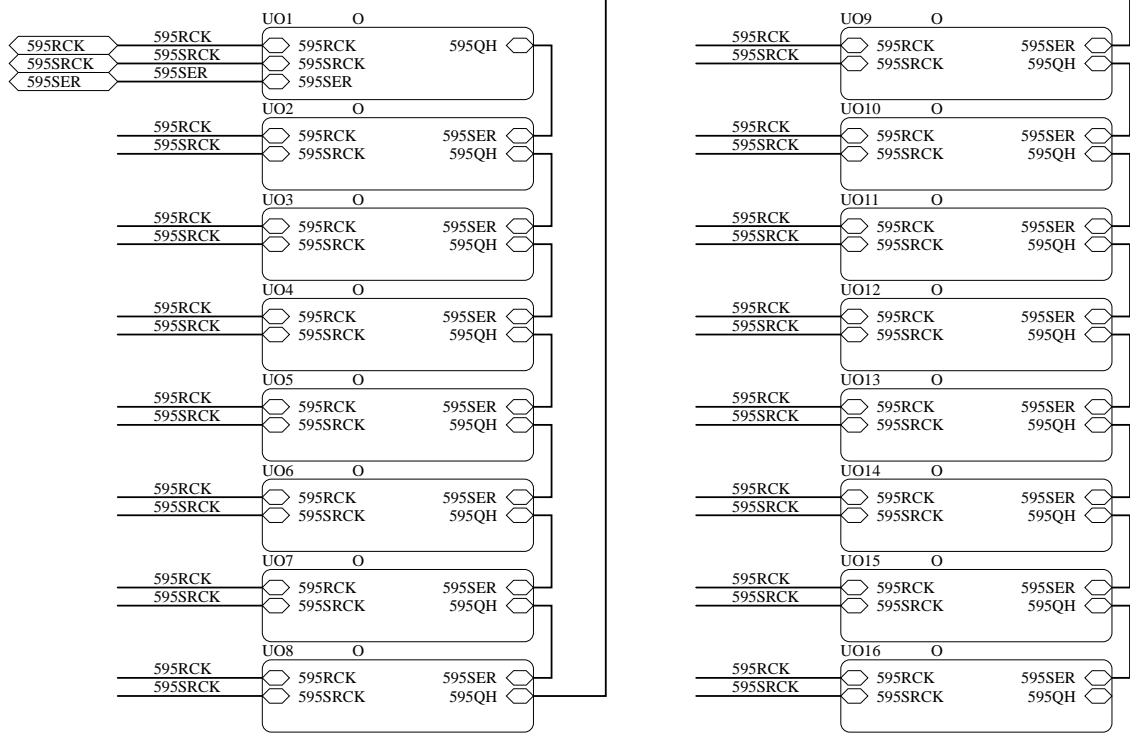

Title		
Size A4	Number	Revision
Date: 3/13/2023	Sheet of	
File: G:\KC868-A256\OUT.SchDoc	Drawn By:	

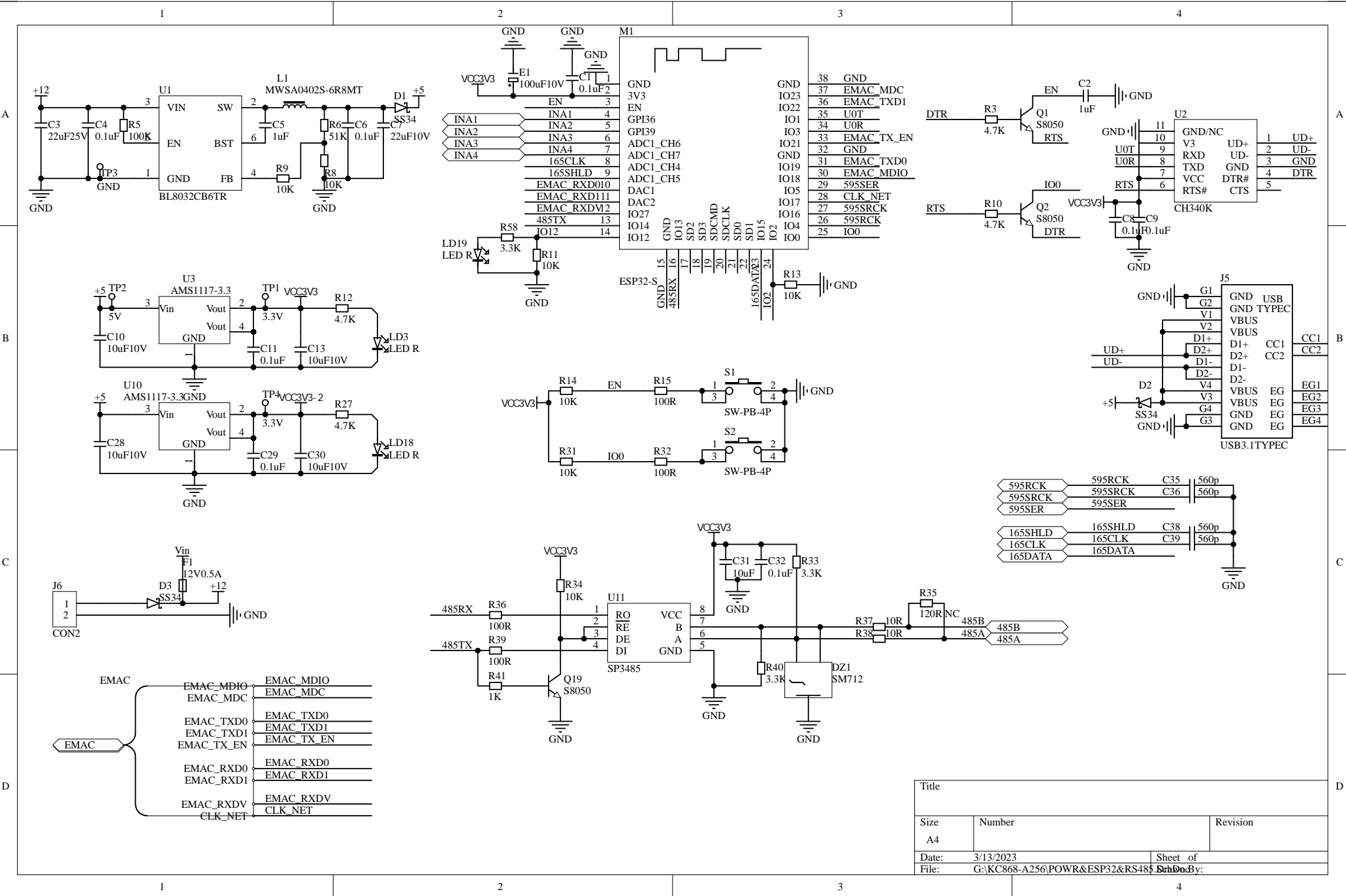

Title		
Size	Number	Revision
A4		
Date:	3/13/2023	Sheet of
File:	G:\KC868-A256\POWR&ESP32&RS485	Rev: 0.01